

### 一：概述

S 型单级双吸泵壳中开之离心泵，供抽送清水或物理化学性质类似于水的其他液体之用。被输送液体温度不得高于 80° C，适用于工厂、矿山、城市给水、电站、农田排灌和各种水利工程。

### 二：结构说明

本型泵的吸入口和吐出口均在水泵的轴心线下方，与轴线垂直成水平方向。检修时无需拆卸进出口水管及电动机。从传动方向看去，水泵为顺时针方向旋转（根据用户需要亦可该为逆时针方向旋转）。

泵的主要零件有：泵体、泵盖、叶轮、轴、双吸密封环、轴套等。除轴的材料为优质碳钢外，其余主要零件为铸铁制成。

泵体与泵盖构成叶轮的工作室。在进出法兰上，制有安装真空表和压力表的管螺孔。进出水法兰的下部，制有放水的管螺孔。

经过静平衡校验的叶轮，用轴套和两边的轴螺母固定的轴上，其轴向位置可通过轴母进行调整。叶轮的轴向力利用叶片对称布置、两面进水达到平衡。

泵轴由两上列向心球轴承支承。轴承装在轴承体内，安装在泵体两端，用黄油润滑。

双吸密封环用以减少水泵压水室的水漏回吸水室。

泵通过弹性联轴器由电机直接传动，必要时亦可用内燃机传动。

轴封为软填料密封，为了防止空气进入泵内和冷却润滑密封腔，在填料之间装有填料环，水泵工作时少量高压水，通过泵盖中开面上的梯形凹槽流入填料室，起水封作用。

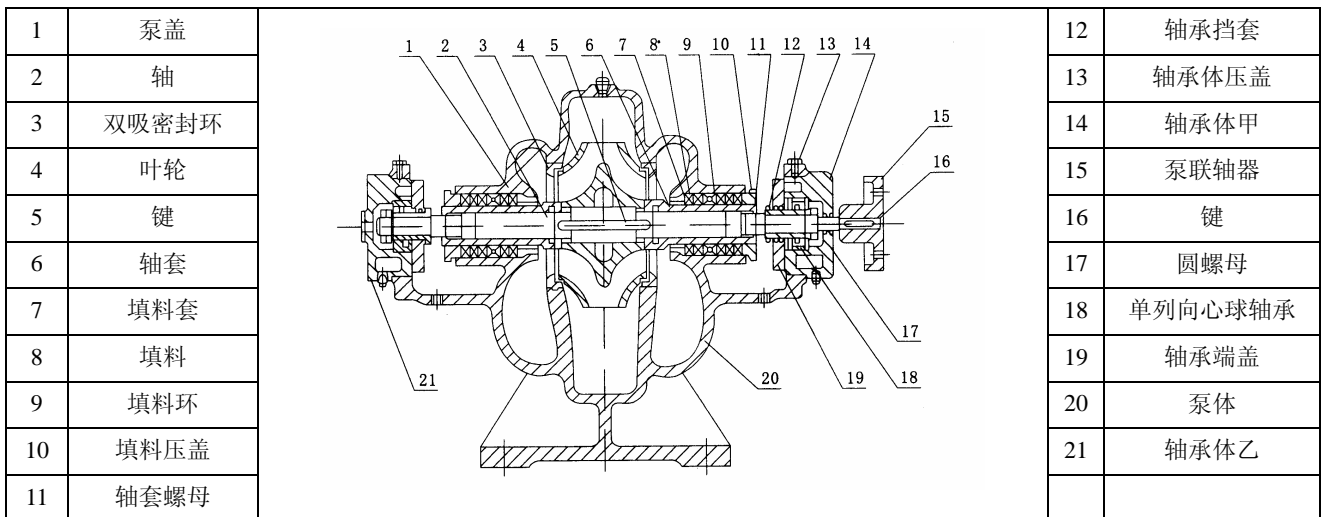

### 三：型号意义

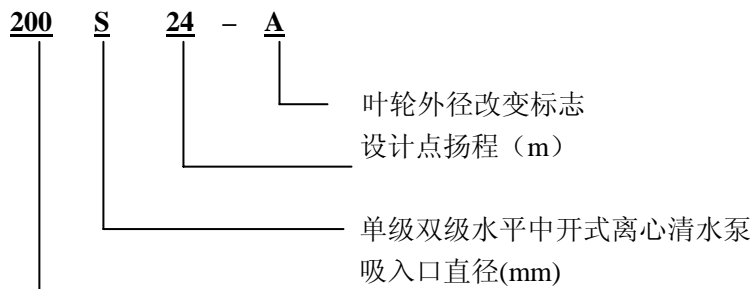

#### 四：装配与拆卸

1、装配转子部件：依次将键、叶轮、轴套、轴套螺母、填料压盖、挡水圈装在轴上，套上双密封环，装上轴承部件和联轴器。

2、分别检查转子部件上叶轮的密封部位外圆的径向跳动，不超过下表规定：

名义直径	≤50	>50-120	>120-260	>260-500	>500-800	>800-1250
跳动量	0.06	0.08	0.10	0.12	0.15	0.20

3、将转子部件螺柱装在泵体上，装好轴承体压盖。用轴套螺母调整叶轮的轴向位置到泵体流道的中间，加以固紧。

4、装上填料，放好中开面纸垫、盖上泵盖，打紧螺尾锥销拧紧泵盖螺母。压紧填料压盖。但不要将填料压得太紧，过紧会使轴套发热，同时耗能增多；也不要压得太松，过松会使液体渗漏过大，水泵效率降低。

5、装配用手转动转子，无卡擦、轻滑均匀即可。

6、拆卸可按上述装配顺序相反进行。

#### 五：安装

1、检查水泵和电机应无损坏。

2、水泵的安装要保证装置提供的汽蚀余量大于泵给定的汽蚀余量值。基础尺寸应符合泵机组的安装尺寸。

3、安装顺序：

(1) 将水泵和电机套上地脚螺栓，戴上螺母，放在预留地脚螺栓孔的混凝土基础上。用调整基间楔形垫块的方法，校正水平，并校好泵上电机轴的同轴度。然后将全部地脚螺孔灌满混凝土。

(2) 待混凝土干固后，在校泵与电机轴的同轴度。在两联轴器外圆上校正，误差不大于 0.1mm。端机间隙沿圆周不均匀度允差 0.3mm。紧固地脚螺母后查校正精度，然后在电机与泵脚底部灌满混凝土，但楔形块周围必须空出。

(3) 检查电机旋向与泵相符合，装上联轴器的连接柱销。

4、进出水管应另设支撑，不得借泵体支撑。

5、泵与管路之间结合面，应保持良好的密封性，尤其是进水管路必须严格保证不漏气，并在装置上应无窝存空气的可能。

6、如水泵装置在进水水位以上时，为了灌了起动，应装底阀。也可采用抽真引水的方法。

以上为不带公共底座的泵机组的安装方法和要求，对于配带公共底座的泵组的安装，参照上述方法进行。

#### 六：启动、停止和运行

(一) 启动与停止：

1、启动前，转动机组转子应轻滑均匀。

2、关闭出水闸阀，灌引水（若无底阀则用真空泵抽气引水），要保证泵内充满水，无空气窝存。

3、如果泵上装有真空泵，要关闭其与泵连接管路上的旋塞，再启动电机，待转速正常后再打开。然后逐渐打开出水闸阀，达到所需流量。

4、均匀地拧紧填料压盖上的螺母，使液体少量漏出，同时注意填料腔的温升。

5、当水泵停止运转时，要先关闭真空表的旋塞和排水管路上的闸阀，然后停止电动机。所处环境的温度较低时，应将泵体下部的四方螺塞打开，以免冻裂泵体。

6、长期停止使用时，应拆开水泵，将零件上的水擦干，在加工表面涂上防锈油。

(二) 运行：

- 1、水泵轴承最高温度不应超过 75℃。
- 2、润滑轴承用的钙基黄油的数量，以占轴承体空间 1/3~1/2 为宜。并应定期更换。
- 3、填料磨损时，可适当压紧填料盖。若磨损过多，应更换。
- 4、定期检查弹性联轴器部件，注意电机轴承温升。
- 5、运转过程中，如发现噪声或其他不正常的声响时，应立即停车，检查原因，加以消除。
- 6、不得任意提高水泵的转速，但可以降低转速使用。

### 七：故障及消除方法

故 障	原因	消除方法
泵不出水，压力表及真空表指针剧烈跳动。	注入泵的水不够，进水管漏气。	再往泵内注水，堵塞漏气处。
泵不吸水，但真空表显示高度真空。	底阀没有打开或淤塞，进水管阻力不大，吸水高度太高。	校平或更换底阀，清洗或更换吸水管，降低吸水高度。
泵不出水，压力表显示有压力。	泵轴旋转方向不对，出水管阻力太大，叶轮淤塞，转数不够。	改正转向，检查水管长度或淤塞，清洗叶轮，增加转数。
泵流量减少或扬程下降。	叶轮或管路阻塞，密封环或叶轮磨损严重，转速低于规定值。	精洗叶轮或管路，更换损坏的零件，调整到额定转速。
泵消耗的功率过大。	填料压得太紧，叶轮与双吸密封环磨损，流量过大。	打松填料压盖，消除机械擦，关小出水闸阀。
泵内声音反常，吸不上水。	吸水高度过高，吸水管漏气，流量过大，发生汽蚀。	减少吸水高度，堵塞漏气处，调节出水闸阀在规定工况用。
泵振动厉害。	泵发生汽蚀，叶轮不平衡，泵电机不同心，地脚螺栓松动。	消除汽蚀，叶轮校平衡，校泵与电机的同轴度，拧紧地脚螺栓。
轴承过热。	润滑油不足或过金，或变质，泵与电机轴不同心	检查油量，清洗轴承并换油，校泵轴与电机的同轴度。

八：S 型单级双吸离心泵性能表

型号	流量 Q (m <sup>3</sup> /h)	扬程 H (m)	转速 n (r/min)	功率(kw)		效率 η (%)	汽蚀余量 (NPSH) <sub>r</sub> (m)
				轴功率	电机功率		
100S90	60	95	2950	25.5	37	61	2.5
	80	90		30.1		65	
	95	84		33.7		64.5	
100S90A	50	78	2950	17.7	30	60	2.5
	72	75		23		64	
	85	70		26		63	
150S100	126	102	2950	50	75	70	3.5
	160	100		59.8		73	
	202	93		68.8		74.4	
150S78	126	82	2950	40	55	70.3	3.5
	160	78		45		75.5	
	198	70		52.4		72	
150S78A	112	67	2950	30	45	68	3.5
	144	62		33.8		72	
	180	55		38.5		70	
150S50	130	52	2950	25.3	37	72.9	3.9
	160	50		27.3		80	
	220	40		31.1		77.2	
150S50A	112	44	2950	18.5	30	72.5	3.9
	144	40		20.9		75	
	180	35		24.5		70	
150S50B	108	38	2950	17.2	22	65	3.9
	133	36		18.6		70	
	160	32		19.4		72	
200S95	183	103	2950	83.1	110	62	5.3
	280	95		91.7		79.2	
	324	87		100		76.8	
200S95A	198	82	2950	65	90	68	5.3
	270	75		73.5		75	
	310	68		77.6		74	
200S63	216	69	2950	54.8	75	74	5.8
	280	63		58.3		82.7	
	351	53		66.4		76.3	
200S63A	180	54.5	2950	38.2	55	70	5.8
	270	.46		45.1		75	
	324	37.5		47.3		70	
200S42	216	48	2950	34.8	45	81	6
	280	42		38.1		84.2	
	342	35		40.2		81	
200S42A	198	43	2950	30.5	37	76	6
	270	36		33.1		80	
	310	31		34.4		76	
250S65	360	71	1450	92.8	132	75	3
	485	65		109		78.6	
	612	58		129.6		74.6	
250S65A	342	61	1450	76.8	110	74	3
	468	54		89.4		77	
	540	50		98		75	
250S39	360	42.5	1450	54.8	75	76	3.2
	485	39		61.5		83.6	
	612	32		68.6		79	
250S39A	324	35.5	1450	42.5	55	74	3.2
	468	30.5		49.3		79	
	576	25		50.9		77	
250S24	360	27	1450	33.1	45	80	3.5
	485	24		36.9		85.8	
	576	19		36.4		85	
250S24A	342	22.2	1450	25.8	37	80	3.5
	414	20.3		27.6		83	
	482	17.4		28.6		80	
250S14	360	16	1450	19.6	30	80	3.8
	485	14		21.5		85.8	
	576	11		22.1		78	
250S14A	320	13.7	1450	15.4	18.5	78	3.8
	432	11		15.8		82	
	504	8.6		15.8		75	
300S110	590	113	1450	248.6	440	73	4
	790	110		295.7		80	
	936	105		326.3		82	
300S90	590	93	1450	202	315	74	4
	790	90		242.8		79.6	
	936	82		279		75	
300S90A	576	86	1450	190	280	71	4
	756	78		217		74	
	918	70		247		71	
300S90B	540	72	1450	151	220	70	4
	720	67		181		73	
	900	57		200		70	
300S58	576	63	1450	136	180	72.7	4.4
	790	58		149.9		84.2	
	972	50		165.5		80	
300S58A	529	53	1450	99.9	160	76.4	4.4
	720	49		118.6		81	
	893	42		131		78	
300S58B	504	46	1450	88.8	132	71.1	4.4
	684	43		100		80	
	835	37		108		78	
300S32	612	36	1450	75	110	80	4.6
	790	32		79.2		86.8	
	900	28		86		80	
300S32A	551	31	1450	58.1	75	80	4.6
	720	26		60.7		74	
	810	24		68		78	
300S19	612	22	1450	45.9	55	80	5.2
	790	19		47		86.8	
	935	16		47.6		85.6	
300S19A	504	20	1450	38.7	45	71	5.2
	720	16		9.2		80	
	829	13		39.1		75	

型号	流量 Q (m <sup>3</sup> /h)	扬程 H (m)	转速 n (r/min)	功率(kw)		效率 η (%)	汽蚀余量 (NPSH) <sub>r</sub> (m)
				轴功率	电机功率		
300S12	612	14.5	1450	30.2	37	80	5.5
	790	12		30.4		84.8	
	900	10		33.1		74	
300S12A	522	11.8	1450	23.3	30	72	5.5
	684	10		23.9		78	
	792	8.7		24.7		76	
350S125	850	140	1450	462	710	70	5.4
	1260	125		534		80.5	
	1660	100		623		72.5	
350S125A	803	125	1450	391	630	70	5.4
	1181	112		462		78	
	1570	90		550		70	
350S125B	745	108	1450	313	500	70	5.4
	1098	96		373		77	
	1458	77		422		72.5	
350S75	972	80	1450	271	355	78	5.8
	1260	75		303		85.2	
	1440	65		319		80	
350S75A	900	70	1450	220	280	78	5.8
	1170	65		247		84	
	1332	56		257		79	
350S75B	828	59	1450	177	220	75	5.8
	1080	55		197		82	
	1224	47.5		206		77	
350S44	972	50	1450	164	220	81	6.3
	1260	44		173		87.5	
	1476	37		189		79	
350S44A	864	41	1450	121	160	80	6.3
	1116	36		131		84	
	1332	30		136		80	
350S26	972	30	1450	99.7	132	79.7	6.7
	1260	26		102		87.5	
	1440	22		105		82	
350S26A	864	26	1450	76.5	90	80	6.7
	1116	21.5		78.8		83	
	1296	16.5		80		73	
350S16	972	20	1450	64	75	83	7.1
	1260	16		64.5		85.3	
	1440	13.4		71		74	
350S16A	864	16	1450	51	55	74	7.1
	1044	13.4		48.8		48	
	1260	10		49		70	
500S98	1620	114	970	644.8	800	78	4
	2020	98		678		79.5	
	2340	79		680.3		74	
500S98A	1500	96	970	509.3	630	77	4
	1872	83		540		78.5	
	2170	67		542.4		73	
500S98B	1400	86	970	431.4	560	76	4
	1746	74		452		78	
	2020	59		432.8		75	
500S59	1620	68	970	379.7	450	79	4.5
	2020	59		391		83	
	2340	47		374.4		80	
500S59A	1500	57	970	315	400	74	4.5
	1872	49		333		75	
	2170	39		320		72	
500S59B	1400	46	970	240.2	315	73	4.5
	1746	40		257		74	
	2020	32		247.9		71	
500S35	1620	40	970	207.6	280	85	4.8
	2020	35		219		88	
	2340	28		209.9		85	
500S35A	1400	31	970	144	220	82	4.8
	1746	27		151		85	
	2020	21		116.9		84	
500S22	1620	24.5	970	140.4	185	77	5.2
	2020	22		144.1		84	
	2340	19.4		145.4		85	
500S22A	1400	20	970	103	132	74	5.2
	1746	17		101		80	
	2020	14		93.9		82	
500S13	1620	15	970	83.8	110	79	5.7
	2020	13		86.2		83	
	2340	10.4		82.8		80	
600S75	3170	75	970	727	800	89	7.5
600S75A	2880	65	970	580	630	88	7.5
600S47	2500	56	970	460	560	83	7.5
	3170	47		465		88	
	3500	38		426		80	
600S32	2520	37	970	295	400	86	7.5
	3170	32		310		89	
	3960	22		279		85	
600S32A	2304	31.5	970	235	280	89	7.5
	2880	27		238		89	
	3600	20		231		89	
600S22	3170	22	970	223	280	85	7.5
600S22A	2880	18.2	970	168.5	200	84.5	7.5

九：性能曲线

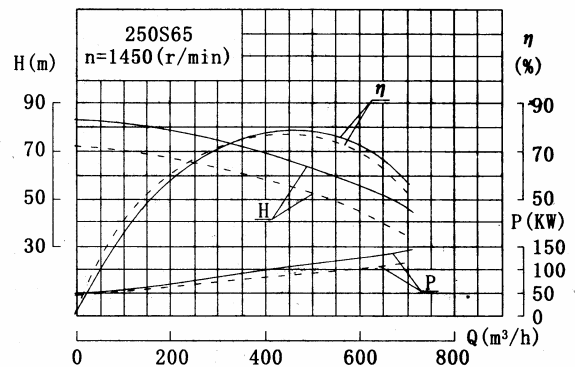
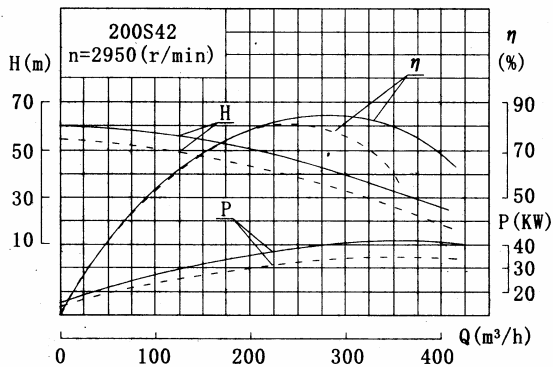
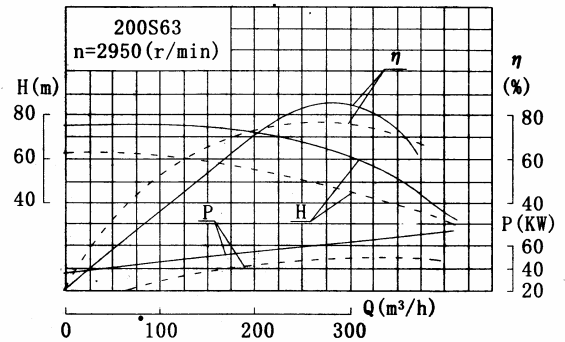
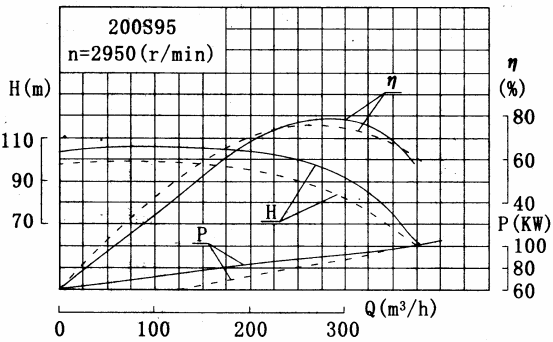
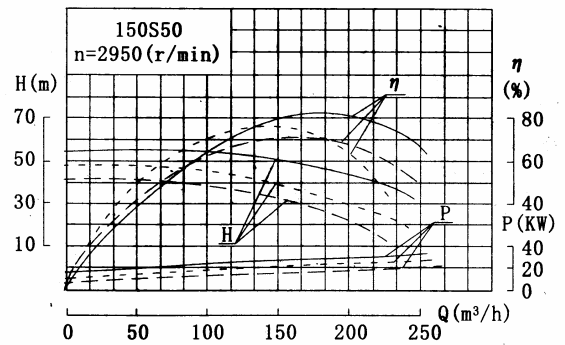
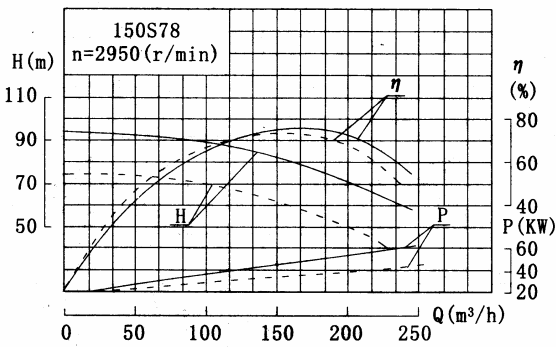
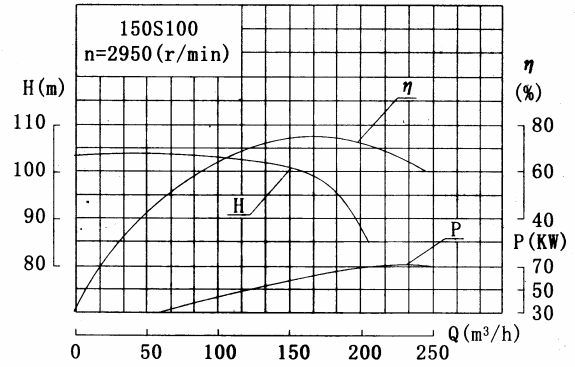
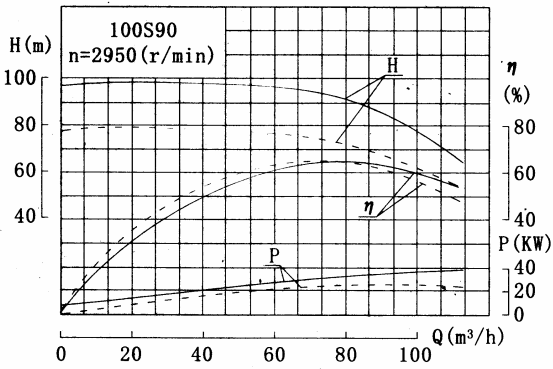

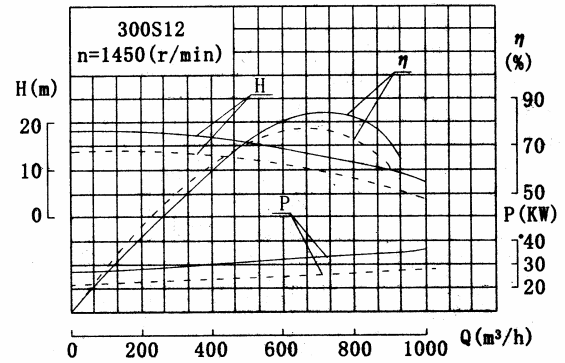
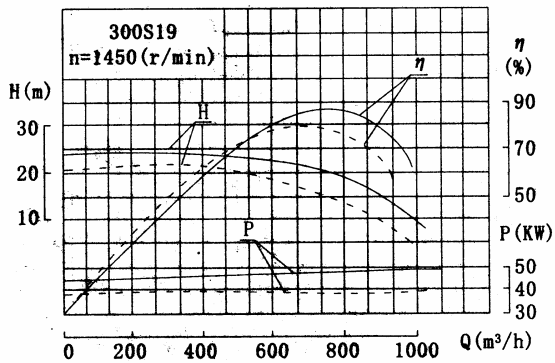
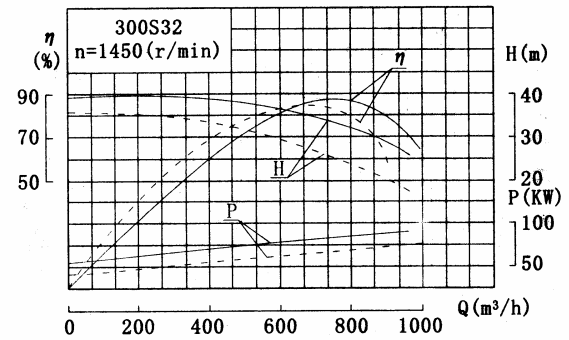
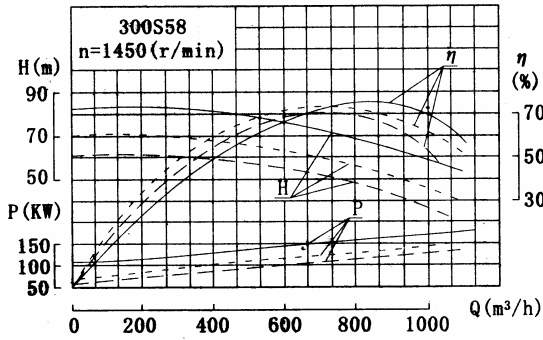
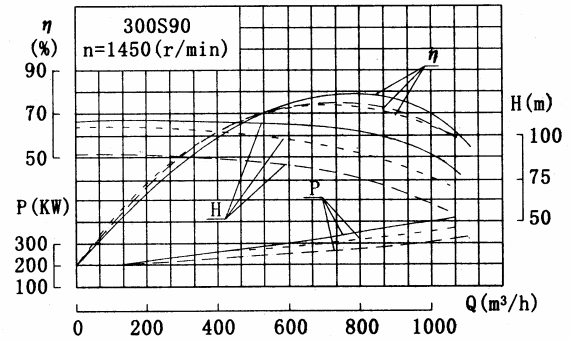
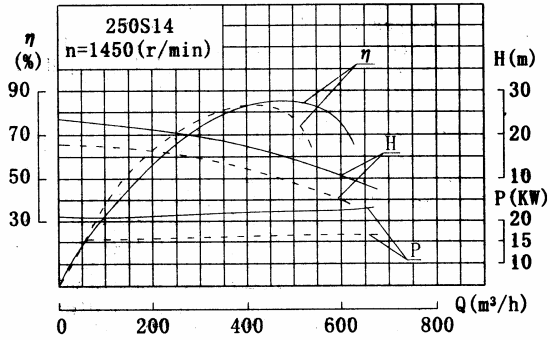
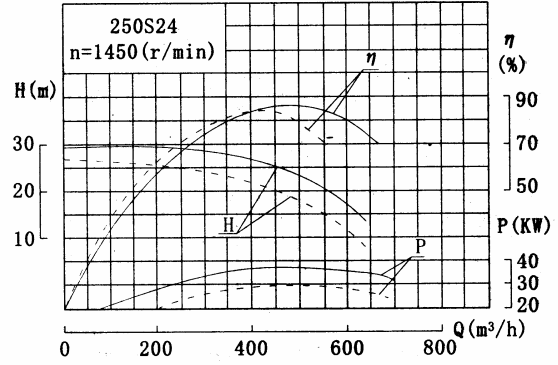
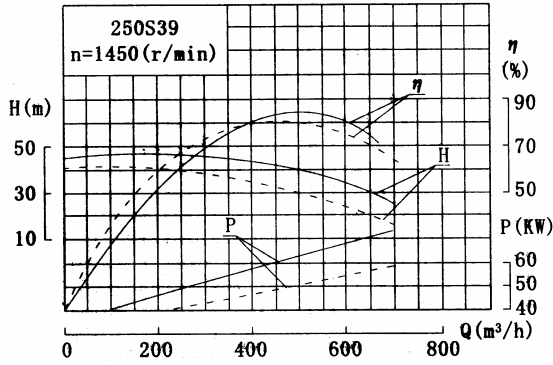

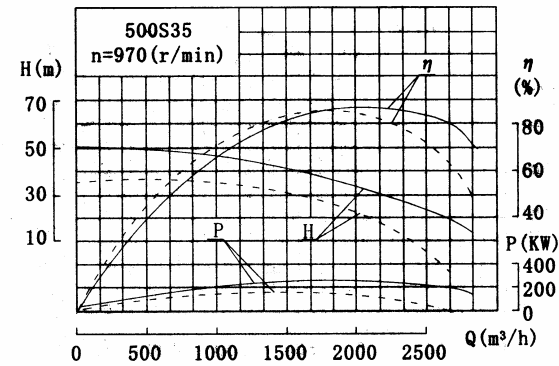
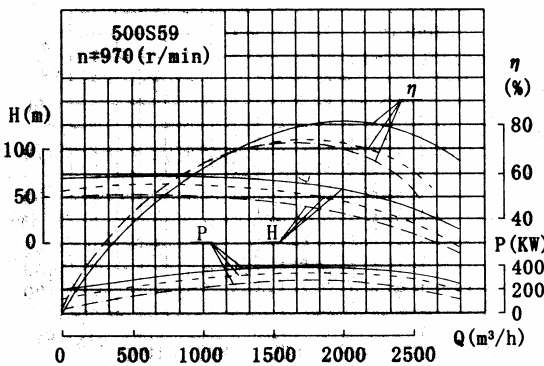
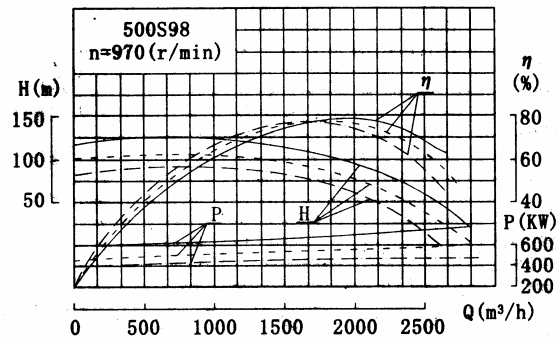
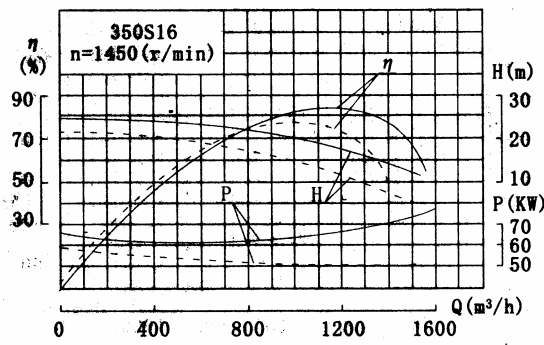
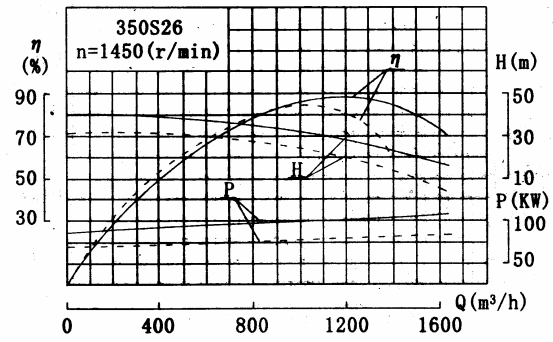
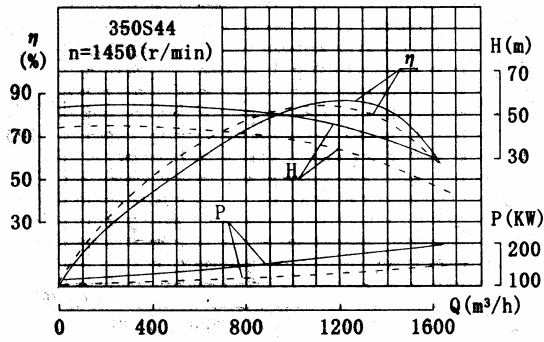
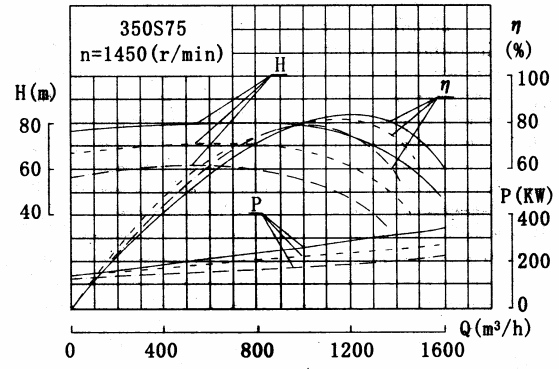
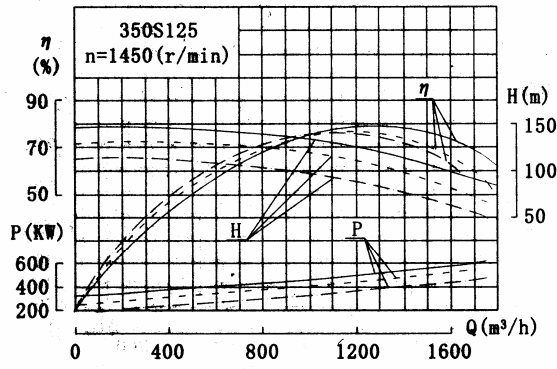



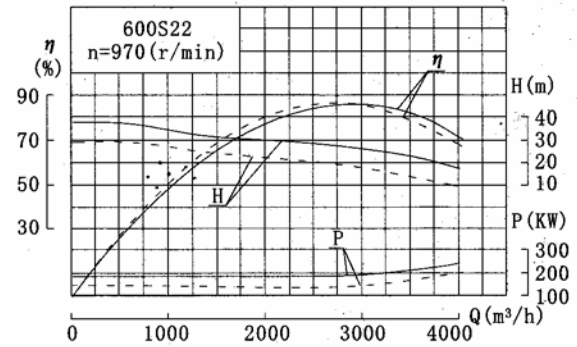
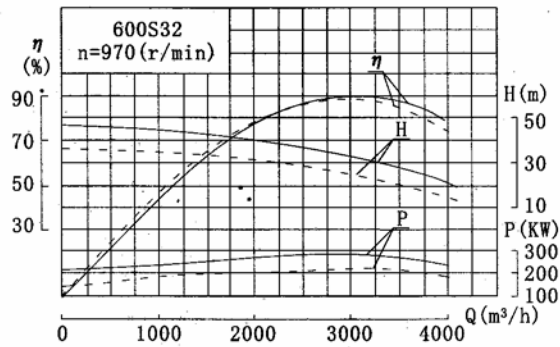
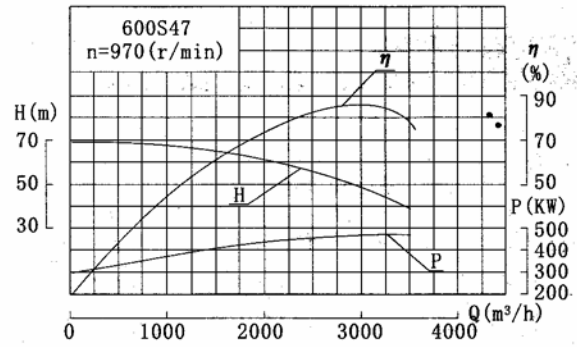
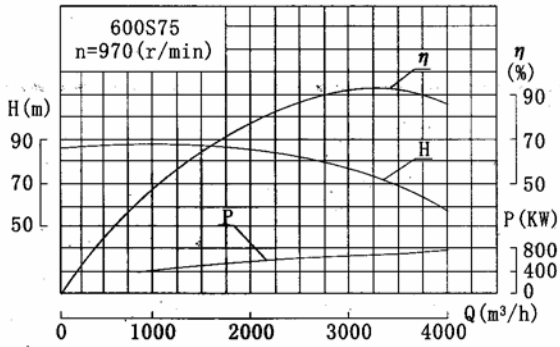
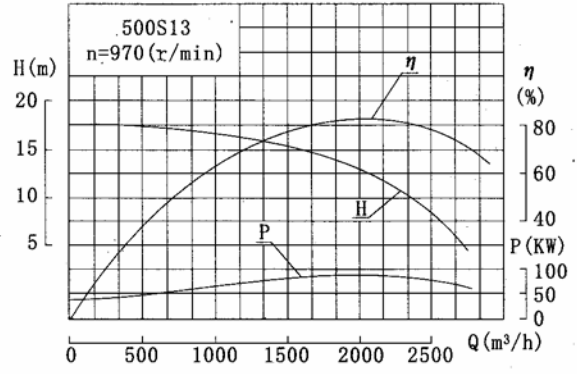
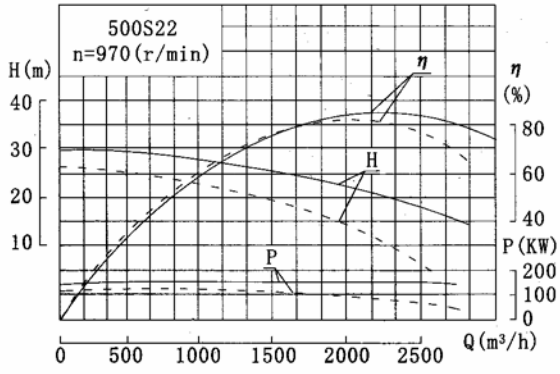

十：外形尺寸图

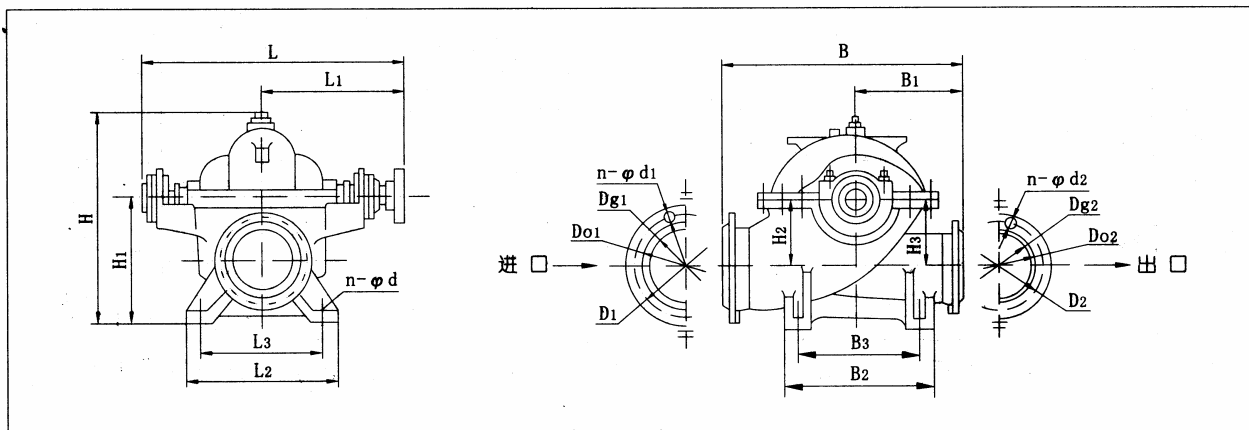

十一：外形尺寸

型号	泵尺寸													进口法兰尺寸				出口法兰尺寸			
	L	L1	L2	L3	B	B1	B2	B3	H	H1	H2	H3	n-Φd	Dg1	Do1	D1	n-Φd1	Dg2	Do2	D2	n-Φd2
100S90	700.5	382	240	190	520	250	300	210	455	265	140	149	4-Φ17.5	400	180	220	8-Φ17.5	70	150	185	4-Φ17.5
150S100	740.5	410	300	250	550	250	340	250	490	285	140	174	4-Φ17.5	150	240	285	8-Φ22	100	180	220	8-Φ17.5
150S78	704.5	388	300	250	550	250	340	250	472.5	285	140	155	4-Φ17.5	150	240	285	8-Φ22	100	180	220	8-Φ17.5
150S50	704.5	388	300	250	550	250	340	250	455	285	140	140	4-Φ17.5	150	240	285	8-Φ22	100	180	220	8-Φ17.5
200S95	861.5	485	300	250	680	330	340	250	555	355	170	170	4-Φ17.5	200	295	340	8-Φ22	125	210	250	8-Φ17.5
200S96	744.5	410	300	250	610	300	340	250	549	355	170	170	4-Φ17.5	200	295	340	8-Φ22	150	240	285	8-Φ22
200S42	744.5	410	300	250	610	300	340	250	547	355	170	170	4-Φ17.5	200	295	340	8-Φ22	150	240	285	8-Φ22
250S65	1046.5	581	410	350	850	400	510	400	796	450	240	300	4-Φ28	250	350	395	12-Φ22	150	240	340	8-Φ22
250S39	983.5	552	410	350	890	440	510	450	750	450	200	260	4-Φ26	250	350	395	12-Φ22	200	295	340	8-Φ22
250S24	953.5	532	410	350	850	400	510	400	738	450	230	230	4-Φ26	250	350	395	12-Φ22	200	295	340	8-Φ22
250S14	882.5	475	410	350	745	330	510	400	709	450	210	215	4-Φ26	250	350	445	12-Φ22	200	295	340	8-Φ22
300S110	1198.5	647	520	450	1152	576	600	450	935	535	268	350	4-Φ27	300	400	445	12-Φ22	200	295	340	12-Φ22
300S90	1188.5	664	520	450	1046	470	600	450	898	510	268	325	4-Φ28	300	400	445	12-Φ22	200	295	340	8-Φ22
300S58	1132	624	510	450	1070	530	620	550	860	510	240	310	4-Φ28	300	400	445	12-Φ22	250	350	395	12-Φ22
300S32	1062.5	574	520	450	880	410	600	450	824	510	260	270	4-Φ26	300	400	445	12-Φ22	250	350	395	12-Φ22
300S19	958.5	517	520	450	900	400	600	450	803	510	250	260	4-Φ26	300	400	445	12-Φ22	250	350	395	12-Φ22
300S12	1008.5	552	520	450	1000	500	660	510	808	510	265	265	4-Φ26	300	400	445	12-Φ22	300	400	445	12-Φ22
350S125	1447.5	830	600	500	1210	550	690	500	1080	620	330	410	4-Φ35	350	460	505	16-Φ22	200	295	340	12-Φ22
350S75	1271.5	710	600	500	1250	600	690	500	1008	620	274	356	4-Φ35	350	460	505	16-Φ22	250	350	395	12-Φ22
350S44	1232.5	675	600	500	1080	510	690	500	980	620	300	300	4-Φ35	350	460	505	16-Φ22	300	400	445	12-Φ22
350S26	1161.5	633	600	500	1040	460	690	500	963	620	290	300	4-Φ35	350	460	505	16-Φ22	300	400	445	12-Φ22
350S16	1090.5	584	600	500	1168	584	690	500	970	620	310	310	4-Φ33	350	460	505	16-Φ22	350	460	505	16-Φ22
500S98	1639.5	912	760	580	1550	750	1020	800	1381	800	425	545	4-Φ42	500	620	670	20-Φ26	300	400	445	12-Φ22
500S59	1637.5	905	760	580	1640	810	1020	800	1300	800	370	480	4-Φ42	500	620	670	20-Φ26	350	460	505	16-Φ22
500S35	1373.5	766	760	580	1350	630	1020	800	1270	800	415	415	4-Φ42	500	620	670	20-Φ26	350	460	505	16-Φ22
50022	1735.5	750	760	580	1450	640	1020	800	1266	800	410	410	4-Φ42	500	620	670	20-Φ26	400	515	565	16-Φ22
500S13	1311.5	717.5	940	760	1550	775	1020	800	1251	800	410	410	4-Φ42	500	620	670	20-Φ26	500	620	670	20-Φ26
600S75	1694.5	940	940	760	1900	940	1020	800	1550	950	425	555	4-Φ42	600	725	780	20-Φ30	400	515	565	16-Φ22
600S47	1694.5	940	940	760	1595	745	1020	800	1505	950	490	490	4-Φ42	600	725	780	20-Φ30	400	515	565	16-Φ22
600S32	169.5	882	940	760	1600	750	1020	800	1490	950	480	480	4-Φ42	600	725	780	20-Φ30	500	620	670	20-Φ26
600S22	1471.5	810	940	760	1790	840	1020	800	1476	950	460	480	4-Φ42	600	725	780	20-Φ30	500	620	670	20-Φ26

十二：安装尺寸图（带底座）

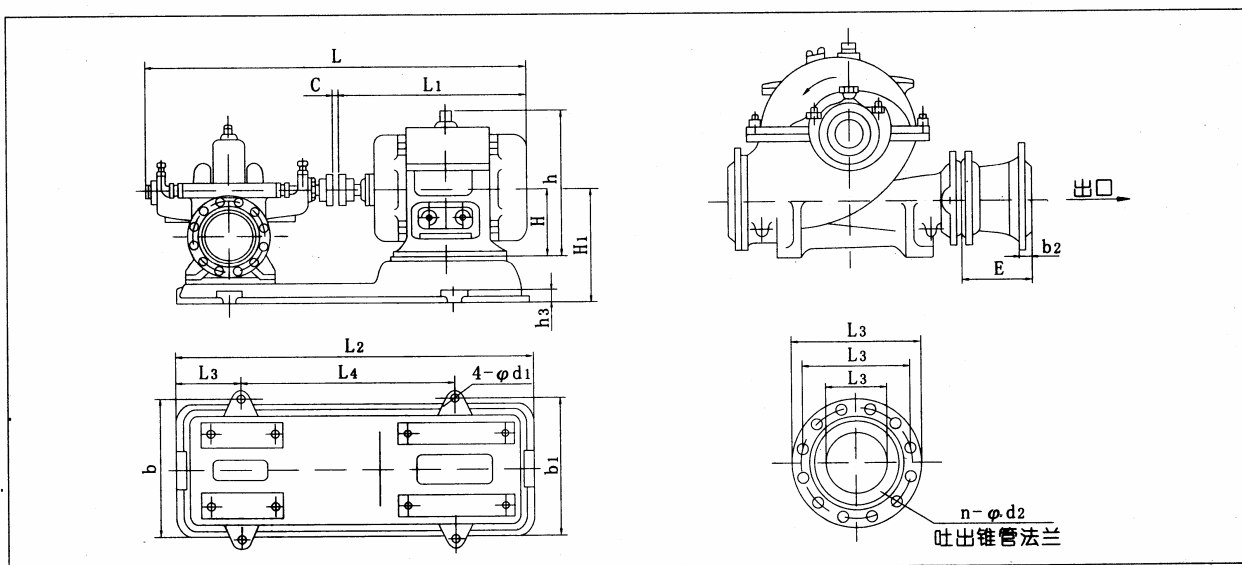

十三：安装尺寸表（带底座）

型号	电动机			电机尺寸			底座尺寸					E	H1	L	吐出锥管法兰尺寸			
	型号	功率	电压	L1	h	H	L2	L3	L4	b	B2				Dg2	Do2	D2	n-Φd2
100S90	Y200L2-2	37	380	775	475	200	1140	141	780.5	385	490	150	365	1479.5	100	180	220	8-Φ17.5
100S90A	Y200L1-2	30	380	775	475	200	1140	141	780.5	385	490	150	365	1479.5	100	180	220	8-Φ17.5
150S100	Y280S-2	75	380	1000	640	280	1390	173	930	430	640	300	385	1744.5	150	240	285	8-Φ22
150S78	Y250M-2	55	380	930	575	250	1305	173	875	430	585	300	385	1638.5	150	240	285	8-Φ22
100S78A	Y225M-2	45	380	815	530	225	1211	173	820	430	540	300	385	1523.5	150	240	285	8-Φ22
150S50	Y200L2-2	37	380	775	475	200	1182	173	800	430	500	300	385	1483.5	150	240	285	8-Φ22
150S50A	Y200L1-2	60	380	775	475	200	182	173	800	430	500	300	385	1483.5	150	240	285	8-Φ22
150S50B	Y180M-2	22	380	670	730	180	1108	173	745	430	465	300	385	1378.5	150	240	285	8-Φ22
200S95A	Y280M-2	90	380	1050	640	280	1523	173	1030	430	680	350	470	1915.5	200	295	340	8-Φ22
200S63	Y280S-2	75	380	1000	640	280	1398	173	930	430	655	350	455	1748.5	200	295	340	8-Φ22
200S63A	Y250M-2	55	380	930	575	250	1335	173	900	430	600	350	455	1678.5	200	295	340	8-Φ22
200S42	Y225M-2	45	380	815	530	225	1408	196	953	472	595	350	455	1563.5	200	295	340	8-Φ22
200S42A	Y200L2-2	37	380	775	475	200	1211	176	810	430	515	350	455	1523.5	200	295	340	8-Φ22
250S39	Y280S-2	75	380	1000	640	280	1636	258	1100	655	720	300	550	1948	250	295	340	8-Φ22
250S39A	Y250M-4	55	380	930	557	250	1586	258	1005	655	665	300	550	1878	250	350	395	12-Φ22
250S24	Y225M-4	45	380	845	530	225	1480	255	950	640	640	300	570	1772.5	250	350	395	12-Φ22
250S24A	Y225S-4	37	380	820	530	225	1420	228	950	600	600	300	550	1747.5	250	350	395	12-Φ22
250S14	Y200L-4	30	380	775	475	200	1340	228	875	600	535	300	550	1661.5	250	350	395	12-Φ22
250S14A	Y180M-4	185	380	670	430	180	1267	228	830	600	495	300	550	1556.5	250	350	395	12-Φ22
300S58	Y315M1-4	180	380	1210	865	315	1965	312	1245	760	870	300	630	2346	300	400	445	12-Φ22
300S32	Y315S-4	110	380	1240	760	315	1845	317	1160	785	785	300	610	2146.5	300	400	445	12-Φ22
300S32A	Y280M-4	75	380	1000	640	280	1767	283	1150	690	690	300	610	2096.5	300	400	445	12-Φ22
300S19	Y250M-4	55	380	930	575	250	1567	283	1005	690	630	300	610	1892.5	300	400	445	12-Φ22
300S19A	Y225M-4	45	380	845	530	225	1503	283	970	690	580	300	610	1807.5	300	400	445	12-Φ22
300S12	Y225S-4	37	380	820	530	225	1566	3005	1000	770	630	-	630	1802.5	-	-	-	-
300S12A	Y200L-4	30	380	775	475	200	1448	283	920	750	545	-	610	1757.5	-	-	-	-
350S26	Y315M1-4	132	380	970	655	280	2015	347	1250	806	806	300	740	2135.5	350	460	505	16-Φ22
350S16	Y280S-4	75	380	1000	640	280	1745	316	1105	790	720	-	740	2100	-	-	-	-
350S16A	Y250M-4	55	380	930	575	250	1677	316	1075	770	670	-	740	2030	-	-	-	-

十四：安装尺寸图（不带底座）

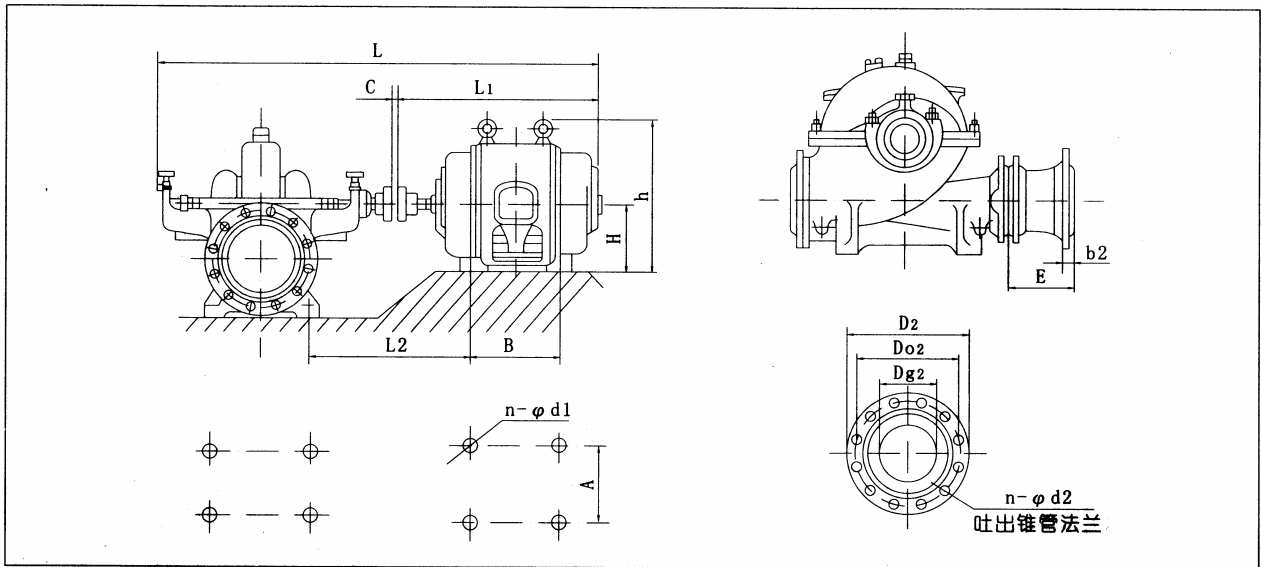

十五：安装尺寸表（不带底座）

型号	C	电动机			电机尺寸						E	L	L2	吐出锥管法兰尺寸			
		型号	功率 KW	电压 V	L1	H	h	B	A	n-Φd				Dg2	Do2	D2	n-Φd2
200S95		Y250M-2(IP23)	110	380	825	250	600	349	406	4-Φ24	375	1690	674	200	295	340	8-Φ22
		Y315S-2	110		1270	315	865	406	508	4-Φ28	375	2060	7501	200	295	340	8-Φ22
		JS2-335S1-2	112		1310	355	850	500	610	4-Φ30	375	2180	7601	200	295	340	8-Φ22
250S65	4	Y280M-4(IP23)	132	380	970	280	655	419	457	4-Φ24	500	2020	772	250	350	395	12-Φ22
		Y315M1-4	132		1270	315	865	457	508	4-Φ28	500	2350	798	250	350	395	12-Φ22
		JS115-4	135		1300	375	875	590	620	4-Φ26	500	2350	872	250	350	395	12-Φ22
		JR115-4	135		1740	375	875	590	620	4-Φ26	500	2790	872	250	350	395	12-Φ22
		JS2-355S2-4	132		1200	355	850	500	610	4-Φ30	500	2250	836	250	350	395	12-Φ22
		JR2-355S2-4	132		1690	355	850	500	610	4-Φ30	500	2740	836	250	350	395	12-Φ22
		Y280S-4(IP23)	110		920	280	655	368	457	4-Φ24	500	1970	772	250	350	395	12-Φ22
		Y315S-4	110		1220	315	865	406	508	4-Φ28	500	2300	798	250	350	395	12-Φ22
		JS114-4	115		1200	375	875	490	620	4-Φ26	500	2250	872	250	350	395	12-Φ22
		JR114-4	115		1640	375	875	490	620	4-Φ26	500	2690	872	250	350	395	12-Φ22
		JS2-355S1-4	112		1200	355	850	500	610	4-Φ30	500	2250	836	250	350	395	12-Φ22
		JR2-355S1-4	112		1690	355	850	500	610	4-Φ30	500	2740	836	250	350	395	12-Φ22
300S110		JS148-4	440	6000	1780	560	1270	870	940	4-Φ42	500	2984	1019	300	400	440	12-Φ22
		Y355M2-7(IP23)	315	380	1290	355	960	560	610	4-Φ28	500	2490	910	300	400	445	12-Φ22
300S90		JS2-400M2-4	320		1440	400	960	630	686	4-Φ36	500	2600	936	300	400	445	12-Φ22
		JR2-400M2-4	320	1880	400	1270	630	686	4-Φ36	500	3080	936	300	400	445	12-Φ22	
300S90A	5	Y355M1-4(IP23)	280	380	1290	355	704	560	610	4-Φ26	500	2490	910	300	400	445	12-Φ22
		JS2-400M2-4	280		1440	400	960	630	686	4-Φ36	500	2600	936	300	400	445	12-Φ22
300S90B		JR2-400M2-4	280	380	1880	400	960	630	686	4-Φ36	500	3080	936	300	400	445	12-Φ22
		Y355M1-4(IP23)	220		1210	315	865	457	508	4-Φ28	500	2410	832	300	400	445	12-Φ22
		JS126-4	225		1300	450	1005	550	710	4-Φ32	500	2500	921	300	400	445	12-Φ22
		JS126-4	225		1740	450	1005	550	710	4-Φ32	500	2940	921	300	400	445	12-Φ22
		JS2-400S1-4	220		1420	560	960	560	686	4-Φ36	500	2620	936	300	400	445	12-Φ22
JR2-400S1-4	220	1810	560	960	560	686	4-Φ36	500	3010	936	300	400	445	12-Φ22			

型号	C	电动机			电机尺寸						E	L	L2	吐出锥管法兰尺寸			
		型号	功率 KW	电压 V	L1	H	h	B	A	n-Φd				Dg2	Do2	D2	n-Φd2
300S58B		Y315M1A-4(IP23)	185	380	1210	315	865	457	508	4-Φ28	300	2355	790	300	400	445	12-Φ22
		JS117-4	180		1345	375	875	640	620	4-Φ26	300	2495	857	300	400	445	12-Φ22
		JR117-4	181		1785	375	875	640	620	4-Φ26	300	2935	857	300	400	445	12-Φ22
		JR2-355M2-4	190		1750	355	850	560	610	4-Φ30	300	2900	821	300	400	445	12-Φ22
300S58A	6	Y315S-4(IP23)	160	380	1160	315	865	409	508	4-Φ28	300	2305	793	300	400	445	12-Φ22
		Y315M2-4	160		1290	315	7601	457	508	4-Φ28	300	2460	793	300	400	445	12-Φ22
		JS115-4	155		1300	375	875	590	620	4-Φ26	500	2450	857	300	400	445	12-Φ22
		JR115-4	155		1740	375	875	590	620	4-Φ26	300	2890	857	300	400	445	12-Φ22
300S58B		JS2-355M1-4	160	380	1260	355	8501	560	610	4-Φ30	300	2410	821	300	400	445	12-Φ22
		JR2-355M1-4	160		1750	355	850	560	610	4-Φ30	300	2900	821	300	400	445	12-Φ22
		Y280M-4(IP23)	132		970	280	655	419	457	4-Φ24	300	2115	767	300	400	445	12-Φ22
		Y315M1-4	132		1290	315	760	457	508	4-Φ28	300	2435	793	300	400	445	12-Φ22
300S58B		JS115-4	135	380	1300	375	875	590	620	4-Φ26	300	2450	857	300	400	445	12-Φ22
		JR115-4	135		1740	375	875	590	620	4-Φ26	300	2890	857	300	400	445	12-Φ22
		JS2-355S2-4	132		1200	355	850	500	610	4-Φ30	300	2350	821	300	400	445	12-Φ22
		JR2-355S2-4	132		1690	355	850	500	610	4-Φ30	300	2840	821	300	400	445	12-Φ22
350S125	7	Y450-50-4	710	6000	2035	450	1350	1120	800	4-Φ35	750	3490	1154	350	470	520	16-Φ22
JS158-4		680	1920		630	1435	1020	1100	4-Φ42	750	3380	1129	350	470	520	16-Φ22	
JR158-4		680	2330		630	1435	1020	1100	4-Φ42	750	3790	1129	350	470	520	16-Φ22	
Y450-46-4		630	2035		450	1350	1120	800	4-Φ35	750	3490	1154	350	470	520	16-Φ22	
350S125A	7	Y400-50-4	500	6000	1860	400	1200	1000	710	4-Φ35	750	3315	1134	350	470	520	16-Φ22
JS1410-4		500	1880		560	1270	970	940	4-Φ42	750	3340	1154	350	470	520	16-Φ22	
JR1410-4		500	2310		560	1270	970	940	4-Φ42	750	3770	1154	350	470	520	16-Φ22	
Y355L-4(IP23)		355	1360		355	704	630	610	4-Φ28	500	2640	932	350	460	505	16-Φ22	
350S75		JS147-4	360	6000	1780	560	1270	870	940	4-Φ42	500	3060	1033	350	460	505	16-Φ22
		JR147-4	360		2210	560	1270	870	940	4-Φ42	500	3490	1033	350	460	505	16-Φ22
		Y355M1-4(IP23)	280		1290	355	704	560	610	4-Φ28	500	2570	932	350	460	505	16-Φ22
350S75A	6	JS128-4	300	6000	1395	450	1005	650	710	4-Φ32	500	2675	943	350	460	505	16-Φ22
		JR128-4	300		1840	450	1005	650	710	4-Φ32	500	3120	943	350	460	505	16-Φ22
		JS2-400M1-4	280		1400	400	960	630	686	4-Φ36	500	2680	958	350	460	505	16-Φ22
		JR2-400M1-4	280		1880	400	960	630	686	4-Φ36	500	3160	958	350	460	505	16-Φ22
350S75B		Y315M1A-4(IP23)	220	6000	1210	315	865	457	508	4-Φ28	500	2490	854	350	460	505	16-Φ22
		JS126-4	225		1295	450	1005	550	710	4-Φ32	500	2575	943	350	460	505	16-Φ22
		JR126-4	225		1740	450	1005	550	710	4-Φ32	500	3020	943	350	460	505	16-Φ22
		JS2-400S1-4	220		1330	400	960	560	686	4-Φ36	500	2610	958	350	460	505	16-Φ22
350S44		JR2-400S1-4	220	380	1810	400	960	560	686	4-Φ36	500	3090	958	350	460	505	16-Φ22
		Y315M1A-7(IP23)	220		1210	315	865	457	508	4-Φ28	500	2490	815	350	460	505	16-Φ22
		JS126-4	225		1295	450	1005	550	710	4-Φ32	500	2575	927	350	460	505	16-Φ22
		JR126-4	225		1740	450	1005	550	710	4-Φ32	500	3020	927	350	460	505	16-Φ22
350S44A	5	JS2-400S1-4	220	380	1330	400	960	560	686	4-Φ36	500	2590	942	350	460	505	16-Φ22
		JR2-400S1-4	220		1810	400	960	560	686	4-Φ36	500	3072	942	350	460	505	16-Φ22
		Y315S-4(IP23)	160		1160	315	860	406	508	4-Φ28	500	2420	815	350	460	505	16-Φ22
		Y315M2-4	160		1290	315	760	457	508	4-Φ28	500	2550	815	350	460	505	16-Φ22
		JS116-4	155		1300	375	875	590	620	4-Φ26	500	2560	912	350	460	505	16-Φ22
		JR116-4	155		1740	375	875	590	620	4-Φ26	500	3000	912	350	460	505	16-Φ22
350S26	7	JS2-355M1-4	160	380	1260	355	850	560	610	4-Φ30	500	2520	876	350	460	505	16-Φ22
		JR2-355M1-4	160		1750	355	850	560	610	4-Φ30	500	3010	876	350	460	505	16-Φ22
		Y280M-4(IP23)	132		970	280	655	419	457	4-Φ24	500	2140	749	350	460	505	16-Φ22
		Y315M1-4	132		1290	315	760	457	508	4-Φ28	500	2460	775	350	460	505	16-Φ22
350S26	7	JS115-4	135	380	1300	375	875	590	620	4-Φ26	500	2470	849	350	460	505	16-Φ22

型号	C	电动机			电机尺寸						E	L	L2	吐出锥管法兰尺寸				
		型号	功率 KW	电压 V	L1	H	h	B	A	n-Φd				Dg2	Do2	D2	n-Φd2	
350S26	7	JR115-4	135	380	1740	375	875	590	620	4-Φ26	500	2910	849	350	460	505	16-Φ22	
		JS2-355S2-4	132		1200	355	850	500	610	4-Φ30	500	2370	813	350	460	505	16-Φ22	
		JR2-355S2-4	132		1690	355	850	500	610	4-Φ30	500	2860	813	350	460	505	16-Φ22	
350S26A	6	Y280M-4	90		1050	280	740	419	457	4-Φ24	500	2220	749	350	460	505	16-Φ22	
		JR115-4	110		1240	315	760	406	508	4-Φ28	500	2410	775	350	460	505	16-Φ22	
		JS2-355S1-4	112		1200	355	850	500	610	4-Φ30	500	2370	813	350	460	505	16-Φ22	
350S16	6	JR2-355S1-4	112		1690	355	850	500	610	4-Φ30	500	2860	813	350	460	505	16-Φ22	
		Y280S-4	75		1000	280	640	368	457	4-Φ24	500	2100	670	350	460	505	16-Φ22	
500S16A	6	Y250M-4	55		930	250	575	349	406	4-Φ24	500	2030	648	350	460	505	16-Φ22	
500S98	5	Y500-54-6	800		6000	2220	500	1500	1250	900	4-Φ42	880	3870	1356	500	620	670	20-Φ26
		Y500-54-6	800			2220	500	1900	1250	900	4-Φ42	880	3890	1356	500	620	670	20-Φ26
		JS1512-6	780			1920	630	1435	1920	1100	4-Φ42	880	3590	1171	500	620	670	20-Φ26
		JS1512-6	7810			2330	630	1435	1020	1100	4-Φ42	880	3590	1171	500	620	670	20-Φ26
500S98A	5	Y450-64-6	630			2080	450	1350	1120	800	4-Φ35	880	3730	1236	500	620	670	20-Φ26
		Y500-50-6	630			2220	500	1900	1250	900	4-Φ42	880	3890	1356	500	620	670	20-Φ26
		JS1510-6	650	1920		630	1435	1020	1100	4-Φ42	880	3590	1171	500	620	670	20-Φ26	
500S98B	5	JR1510-6	650	2330		630	1435	1020	1100	4-Φ42	880	4000	1171	500	620	670	20-Φ26	
		Y450-54-6	560	2080		450	1350	1120	800	4-Φ35	880	3730	1236	500	620	670	20-Φ26	
		Y450-46-6	560	2080		450	1650	1120	800	4-Φ35	880	3750	1236	500	620	670	20-Φ26	
500S59	5	JS158-6	550	1920		630	1435	1020	1100	4-Φ42	880	3590	1171	500	620	670	20-Φ26	
		JR158-6	550	2330		630	1435	1020	1100	4-Φ42	880	4000	1171	500	620	670	20-Φ26	
		Y450-54-6	450	2080		450	1350	1120	800	4-Φ35	800	3730	1229	500	620	670	20-Φ26	
500S59A	5	Y450-46-6	450	2080		450	1650	1120	800	4-Φ35	800	3750	1229	500	620	670	20-Φ26	
		JS157-6	460	1720		630	1435	820	1100	4-Φ42	800	3390	1159	500	620	670	20-Φ26	
		JR157-6	460	2130	630	1435	820	1100	4-Φ42	800	3800	1159	500	620	670	20-Φ26		
500S59B	7	Y400-54-6	400	1860	400	1200	1000	610	4-Φ35	800	3510	1169	500	620	670	20-Φ26		
		Y400-46-6	400	2080	450	1650	1120	800	4-Φ35	800	3750	1229	500	620	670	20-Φ26		
		JS1410-6	380	1880	560	1270	970	940	4-Φ42	800	3550	1189	500	620	670	20-Φ26		
500S59B	7	JR1410-6	380	2310	560	1270	970	940	4-Φ42	800	3980	1189	500	620	670	20-Φ26		
		Y400-46-6	315	1860	400	1200	1000	710	4-Φ35	800	3510	1169	500	620	670	20-Φ26		
		Y400-50-6	315	1860	400	1450	1000	710	4-Φ35	800	3530	1169	500	620	670	20-Φ26		
500S35	6	JS148-6	310	1780	560	1270	870	940	4-Φ42	800	3450	1189	500	620	670	20-Φ26		
		JR148-6	310	2210	560	1270	870	940	4-Φ42	800	3880	1189	500	620	670	20-Φ26		
		YS355L1-6(IP23)	280	1360	355	704	630	610	4-Φ28	800	2760	948	500	620	670	20-Φ26		
500S35A	6	YS355R1-6(IP23)	280	1670	355	855	630	610	4-Φ28	800	3070	948	500	620	670	20-Φ26		
		JS137-6	280	1520	500	1125	760	790	4-Φ32	800	2920	989	500	620	670	20-Φ26		
		JR137-6	280	1960	500	1125	760	790	4-Φ32	800	3360	989	500	620	670	20-Φ26		
500S35A	6	JS2-400M3-6	280	1400	400	960	630	686	4-Φ32	800	2800	974	500	620	670	20-Φ26		
		JR2-400M3-6	280	1880	400	960	630	686	4-Φ32	800	3280	948	500	620	670	20-Φ26		
		YS355M1-6(IP23)	220	1290	355	704	560	610	4-Φ28	800	2690	948	500	620	670	20-Φ26		
500S22	5	YS355M1-6(IP23)	220	1670	355	835	560	610	4-Φ28	800	3070	974	500	620	670	20-Φ26		
		JS128-6	215	1310	450	1005	650	710	4-Φ32	800	2710	974	500	620	670	20-Φ26		
		JR128-6	215	1760	450	1005	650	710	4-Φ32	800	3160	974	500	620	670	20-Φ26		
500S22	5	JS2-400S3-6	220	1330	400	960	560	686	4-Φ36	800	2730	974	500	620	670	20-Φ26		
		JR2-400S3-6	220	1810	400	960	560	686	4-Φ36	800	3210	974	500	620	670	20-Φ26		
		Y315M1-6(IP23)	185	1290	355	704	450	610	4-Φ28	600	2690	931	500	620	670	20-Φ26		
500S22	5	JS127-6	185	1410	450	1005	650	710	4-Φ32	600	2810	957	500	620	670	20-Φ26		
		JR127-6	185	1860	450	1005	650	710	4-Φ32	600	3260	957	500	620	670	20-Φ26		

型号	C	电动机			电机尺寸						E	L	L2	吐出锥管法兰尺寸			
		型号	功率 KW	电压 V	L1	H	h	B	A	n-Φd				Dg2	Do2	D2	n-Φd2
500S22A		JS2-400S2-6	190	380	1330	400	960	560	686	4-Φ36	600	2730	957	500	620	670	20-Φ26
		JR2-400S2-6	190		1810	400	960	560	686	4-Φ36	600	3210	957	500	620	670	20-Φ26
500S22	5	Y315M1-6(IP23)	132	380	1210	315	865	457	508	4-Φ28	600	2590	853	500	620	670	20-Φ26
		Y315M3-6	132		1270	315	760	457	508	4-Φ28	600	2640	857	500	620	670	20-Φ26
		JS125-6	130		1310	450	1005	550	710	4-Φ32	600	2680	957	500	620	670	20-Φ26
		JR125-6	130		1760	450	1005	550	710	4-Φ32	600	3130	957	500	620	670	20-Φ26
		JS2-355M2-6	132		1260	355	850	560	610	4-Φ30	600	2630	891	500	620	670	20-Φ26
		JR2-355M2-6	132		1750	355	850	560	610	4-Φ30	600	3120	891	500	620	670	20-Φ26
600S13		Y315S-6(IP23)	110	6000	1160	315	865	406	508	4-Φ28	600	2480	820.5	500	620	670	20-Φ26
		Y315M2-6	110		1270	315	760	457	508	4-Φ28	600	2580	820.5	500	620	670	20-Φ26
		JS117-6	115		1200	355	875	590	620	4-Φ26	600	2510	894.5	500	620	670	20-Φ26
		JR117-6	115		1640	355	875	590	620	4-Φ26	600	2950	894.5	500	620	670	20-Φ26
		JS2-355M1-6	112		1260	355	850	560	610	4-Φ30	600	2570	858.5	500	620	670	20-Φ26
		JR2-355M1-6	112		1750	355	850	560	610	4-Φ30	600	3060	858.5	500	620	670	20-Φ26
600S75A		Y450-64-6	800	6000	2220	500	1500	1250	900	4-Φ42	600		1294	500	620	670	20-Φ26
		Y500-64-6	800		2220	500	1900	1250	900	4-Φ42	600		1294	500	620	670	20-Φ26
		JS1512-6	780		1920	630	1432	1020	1100	4-Φ42	600		1109	500	620	670	20-Φ26
		JR1512-6	780		2330	630	1432	1020	1100	4-Φ42	600		109	500	620	670	20-Φ26
600S75	7	Y450-64-6	630	6000	2080	450	1350	1120	800	4-Φ35	600		1174	500	620	670	20-Φ26
		Y500-50-6	630		2220	500	1900	1250	900	4-Φ42	600		1294	500	620	670	20-Φ26
		JS1510-6	650		1920	630	1432	1020	1100	4-Φ42	600		1109	500	620	670	20-Φ26
600S47		Y450-54-6	560	6000	2080	450	1350	1120	800	4-Φ35	600		1174	500	620	670	20-Φ26
		Y450-65-6	560		2080	450	1650	1120	800	4-Φ35	600		1174	500	620	670	20-Φ26
		JS158-6	550		1920	630	1435	1020	1100	4-Φ42	600		1109	500	620	670	20-Φ26
		JR158-6	550		2330	630	1435	1020	1100	4-Φ42	600		1109	500	620	670	20-Φ26
600S32		Y450-54-6	400	6000	1860	400	1200	1000	710	4-Φ35	600		1055	500	620	670	20-Φ26
		Y500-64-6	400		2080	450	1650	1120	800	4-Φ35	600		1115	500	620	670	20-Φ26
		JS1410-6	380		1880	560	1270	970	940	4-Φ42	600		1075	500	620	670	20-Φ26
		JR1410-6	380		2310	560	1260	970	940	4-Φ42	600		1075	500	620	670	20-Φ26
600S32 A	6	Y400-43-6	280	380	1860	400	1200	1000	710	4-Φ35	600		1055	500	620	670	20-Φ26
		Y355L1-6(IP23)	280		1360	355	704	630	610	4-Φ28	600		974	500	620	670	20-Φ26
		JS137-6	280		1520	500	1125	760	790	4-Φ32	600		1015	500	620	670	20-Φ26
		JR137-6	280		1960	500	1125	760	790	4-Φ32	600		1015	500	620	670	20-Φ26
		JS2-40M3-6	280		1400	400	960	730	686	4-Φ32	600		1000	500	620	670	20-Φ26
		JR2-40M3-6	280		1880	400	960	730	686	4-Φ32	600		1000	500	620	670	20-Φ26
600S22		Y355L1-6(IP23)	280	380	1760	355	704	730	610	4-Φ28	600		974	500	620	670	20-Φ26
		Y355L1-6(IP23)	280		1360	355	707	730	610	4-Φ28	600		902	500	620	670	20-Φ26
		Y355L1-6(IP23)	280		1760	355	704	730	610	4-Φ28	600		902	500	620	670	20-Φ26
		JS137-6	280		1520	500	1125	760	790	4-Φ32	600		943	500	620	670	20-Φ26
		JR137-6	280		1960	500	1125	760	790	4-Φ32	600		943	500	620	670	20-Φ26
		JS2-4003-6	280		1400	400	960	730	686	4-Φ32	600		938	500	620	670	20-Φ26
600S22A		JR2-4003-6	280	380	1880	400	960	730	686	4-Φ32	600		938	500	620	670	20-Φ26
		Y355M2-6(IP23)	200		1290	355	704	560	610	4-Φ28	600		902	500	620	670	20-Φ26
		Y355M2-6(IP23)	200		1690	355	704	560	610	4-Φ28	600		9025	500	620	670	20-Φ26
		JS2-400S3-6	190		13330	400	960	560	686	4-Φ36	600		928	500	620	670	20-Φ26
JR2-400S3-6	190	1810	400	960	560	686	4-Φ36	600		928	500	620	670	20-Φ26			